

1326136-1 ✓ ACTIVE

AMP 0.64 Connector System

TE Internal #: 1326136-1

Automotive Connector Caps & Covers, Shield Assembly, Cable Exit Angle 70°, Black, Nylon GF, 26 Position, AMP 0.64 Connector System

[View on TE.com >](#)



Connectors > Automotive Connectors > Connector Accessories > Connector Caps & Covers



Protection & Strain Relief Accessory Type: **Shield Assembly**

Cable Exit Angle: **70°**

Strain Relief: **With**

Primary Product Color: **Black**

Primary Product Material: **Nylon GF**

### Features

#### Product Type Features

Protection & Strain Relief Accessory Type	Shield Assembly
-------------------------------------------	-----------------

#### Configuration Features

Compatible With Connector Code	A-E
Number of Positions	26

#### Body Features

Cable Exit Angle	70°
Primary Product Color	Black
Primary Product Material	Nylon GF

#### Mechanical Attachment

Strain Relief	With
---------------	------

#### Packaging Features

Packaging Quantity	1
Packaging Method	Package



Other

Serviceable	No
-------------	----

Product Compliance

[For compliance documentation, visit the product page on TE.com>](#)

EU RoHS Directive 2011/65/EU	Compliant
EU ELV Directive 2000/53/EC	Compliant
China RoHS 2 Directive MIIT Order No 32, 2016	No Restricted Materials Above Threshold
EU REACH Regulation (EC) No. 1907/2006	Current ECHA Candidate List: JUNE 2022 (224) Candidate List Declared Against: JUNE 2022 (224) Does not contain REACH SVHC
Halogen Content	Low Halogen - Br, Cl, F, I < 900 ppm per homogenous material. Also BFR/CFR/PVC Free
Solder Process Capability	Not applicable for solder process capability

Product Compliance Disclaimer

This information is provided based on reasonable inquiry of our suppliers and represents our current actual knowledge based on the information they provided. This information is subject to change. The part numbers that TE has identified as EU RoHS compliant have a maximum concentration of 0.1% by weight in homogenous materials for lead, hexavalent chromium, mercury, PBB, PBDE, DBP, BBP, DEHP, DIBP, and 0.01% for cadmium, or qualify for an exemption to these limits as defined in the Annexes of Directive 2011/65/EU (RoHS2). Finished electrical and electronic equipment products will be CE marked as required by Directive 2011/65/EU. Components may not be CE marked. Additionally, the part numbers that TE has identified as EU ELV compliant have a maximum concentration of 0.1% by weight in homogenous materials for lead, hexavalent chromium, and mercury, and 0.01% for cadmium, or qualify for an exemption to these limits as defined in the Annexes of Directive 2000/53/EC (ELV). Regarding the REACH Regulation, the information TE provides on SVHC in articles for this part number is based on the latest European Chemicals Agency (ECHA) 'Guidance on requirements for substances in articles' posted at this URL: <https://echa.europa.eu/guidance-documents/guidance-on-reach>

Compatible Parts

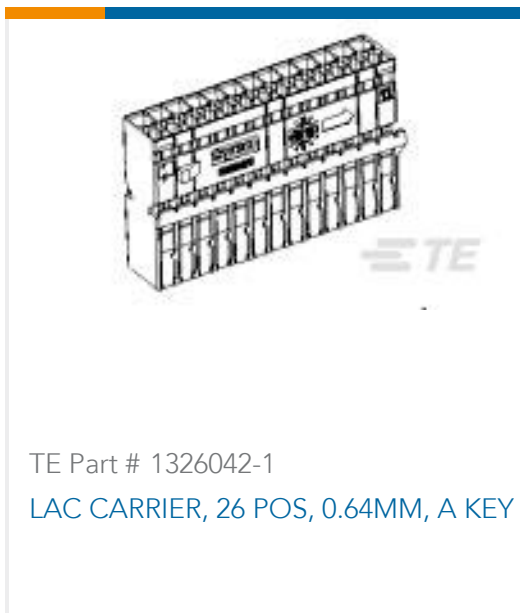

Also in the Series | [AMP 0.64 Connector System](#)

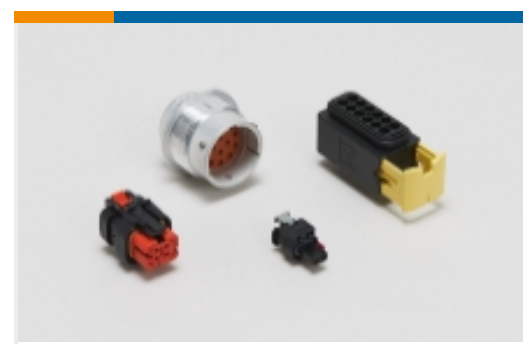
Automotive Connector Caps & Covers  
(19)

Automotive Housings(31)



Automotive Terminals(13)

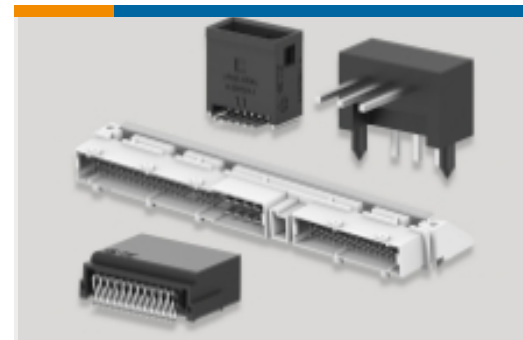

Insertion &amp; Extraction Tools(1)

Other Automotive Connector  
Accessories(1)

PCB Headers &amp; Receptacles(38)

## Documents

### Product Drawings

#### 26WAY LAC "SINGLE GEAR" ASMBLY

English

### CAD Files

#### 3D PDF

3D

#### Customer View Model

[ENG\\_CVM\\_CVM\\_1326136-1\\_B.2d\\_dxf.zip](#)

English

#### Customer View Model

[ENG\\_CVM\\_CVM\\_1326136-1\\_B.3d\\_igs.zip](#)

English

#### Customer View Model

[ENG\\_CVM\\_CVM\\_1326136-1\\_B.3d\\_stp.zip](#)

English

By downloading the CAD file I accept and agree to the [Terms and Conditions](#) of use.

### Instruction Sheets

#### Instruction Sheet (U.S.)

English